



# TOPIC OVERVIEW: 7.2 MICROBIT PROGRAMMING

## What **BIG IDEAS** will you cover in this topic?

In this exciting topic, you'll learn how to program a Micro:bit – a mini computer with buttons, lights, and sensors. You'll bring it to life by making it scroll messages, show built-in or custom images, create animations, and even react to button presses and random choices. Using Python, you'll develop coding skills while building digital pets, nightlights, mood checkers, and more. You'll be thinking logically, creatively, and interactively!

## What **prior knowledge** will you use from your prior learning?

You'll use basic knowledge of how computers follow instructions and your understanding of numbers and logic. If you're familiar with simple math and how technology works, this will help you understand how to program the Microbit to do various tasks.

## Where does this topic fit into the **curriculum plan** for this subject?

In Year 7, from January to April. This topic introduces fundamental programming concepts using the Microbit, laying the groundwork for more advanced programming and technology projects. It helps you understand how computers follow instructions and how you can control them to create interactive and engaging projects.

## What is the **key vocabulary** that you will need to know in this topic?

Micro:bit, Python, Scroll, Display, Image, Variable, List, Loop, Sleep, If Statement, Button Input, Animation, Brightness Grid, Debug, Random, Sequence, Selection, Iteration

## What other **key concepts, knowledge and skills** will you learn in this topic?

- **Scrolling Text** – Use `display.scroll()` to show messages on the Micro:bit screen in sequence
- **Built-in Image Library** – Use `display.show()` to show emojis, animals, shapes, and other fun icons
- **Custom Image Design** – Create your own pixel images using brightness values on a 5x5 grid
- **Animations** – Use loops and lists to show image sequences like fireworks or moving stickmen
- **Variables** – Store and update values like moods, names, and movement steps
- **Selection (If Statements)** – Make the Micro:bit respond differently based on button inputs or random outcomes
- **User Interaction** – Build real-time experiences using button presses and the Micro:bit features

## Assessment:

### How and when will you be assessed on this topic?

- **Quizzes:** Short quizzes to test your understanding of key concepts like sequencing and variables.
- **Practical Activities:** Hands-on tasks to program the Microbit to complete specific functions, such as making a simple game or interactive project.
- **Projects:** Create a project using the Microbit that involves sequencing, variables, iteration, and the accelerometer to demonstrate your coding skills.
- **Assessment:** On the computer, there will be an end of term assessment.

## What is the **structure of learning/lessons** in this topic?

- 7.2.1 – Scrolling Text:
- 7.2.2 – Image Library:
- 7.2.3 – Custom Images & Animation:
- 7.2.4 – Choices and Interaction:

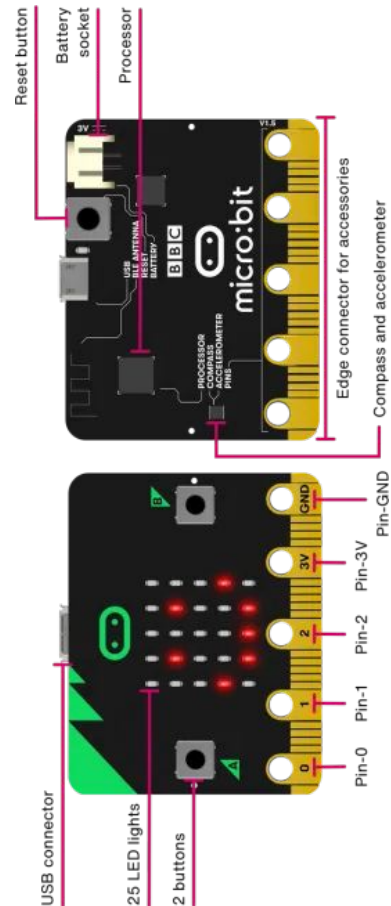

# TOPIC OVERVIEW: 7.3 SPREADSHEETS

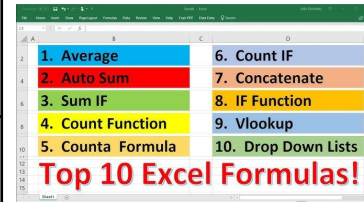
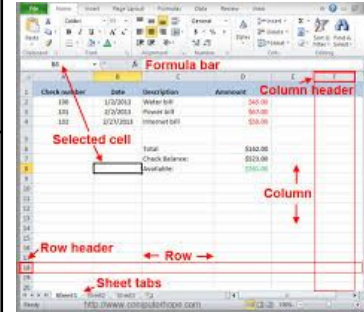

## What **BIG IDEAS** will you cover in this topic?

In this topic, you'll unlock the power of spreadsheets — one of the most useful tools in computing and the real world. You'll learn how to organise data, create colourful charts, write smart formulas, and even build an interactive quiz. By the end of the unit, you'll be able to use spreadsheets to solve problems, model scenarios, and present data clearly and professionally.

## What other **key concepts, knowledge and skills** will you learn in this topic?

- **Data Entry & Formatting** – Enter data clearly and format it professionally using colours, borders, and alignment.
- **Basic Formulas** – Use formulas like =SUM, =AVERAGE, =MAX, and =MIN to perform calculations.
- **Graphs & Charts** – Create bar, pie, and line graphs with titles and labels to present data visually.
- **Advanced Formulas** – Apply =COUNT, =COUNTIF, and =VLOOKUP to analyse and search data.
- **Interactivity** – Build quizzes using drop-down lists, =IF statements, and conditional formatting for instant feedback.

## What **prior knowledge** will you use from your prior learning?

You'll build on your understanding of:

- Basic digital skills (navigating files and editing documents)
- Logical thinking and using simple maths
- Presenting and formatting information clearly
- If you've ever used tables or followed step-by-step instructions in apps, you're already prepared!

## Assessment:

### How and when will you be assessed on this topic?

- **Silent Starter Challenges** – Quick checks on your formula knowledge
- **Practical Tasks** – Each lesson includes a hands-on spreadsheet task
- **Workbook Evidence** – Screenshots and written explanations of your work
- **End-of-Unit Project** – Create your own interactive quiz with formulas, formatting, and validation

## Where does this topic fit into the **curriculum plan** for this subject?

In Year 7, from April to June. It's one of the most useful topics you'll do — spreadsheets are used in science, business, sports, budgeting, and even game design. These skills will help you in future projects, exams, and even everyday life.

## What is the **key vocabulary** that you will need to know in this topic?

Spreadsheet, Cell Reference, Formula, SUM, AVERAGE, MAX, MIN, COUNT, COUNTIF, VLOOKUP, IF Statement, Validation, Drop-down List, Conditional Formatting, Graph, Axis, Title, Chart Type, Merge, Wrap, Currency Format

## What is the **structure of learning/lessons** in this topic?

- 7.3.1 – Spreadsheet Superpowers
- 7.3.2 – Graphs:
- 7.3.3 – Formula Fun:
- 7.3.4 – Data Detective:
- 7.3.5 – Interactive Quiz: